

Diaphragm Valve WT SBM-PTV

Diaphragm valve generally refers to a valve having a diaphragm of rubber or other flexible material that opens or closes the fluid passage. Diaphragm valves are used on shut-off and throttling service for liquids, slurries and vacuum/gas. The seal is achieved by a flexible membrane, usually elastomer, and possibly reinforced with a metal part. The membrane is tensed by the effect of a stem/compressor with lineal movement until contact is made against the seal of the body. The operating parts of the diaphragm valve are isolated from the flow. This makes this valve suitable for viscous flows and also hazardous, abrasive and corrosive flows as its sealing system avoids any contamination towards or from the environment. Diaphragm valves are available in a wide variety of metals, solid plastics, plastic, rubber and glass linings. They are well suited to the handling of multiple chemical applications both clear fluids as well as slurries. The diaphragm valve has an extended use for applications at low pressures and slurry fluid where most other kinds of valves corrode or become obstructed.

Weir type diaphragm valve

- Basic structure of diaphragm valve having a weir at the fluid passage. The diaphragm and weir of the body are tightly closed for air tightness to achieve high valve seat sealing performance.
- Rich selection is available for the main body and diaphragm material to apply to a wide scope of fluid.
- Used for: Chemical, environment and water treatment, iron and steel, shipbuilding, medical, food, semiconductor, power generation, etc.

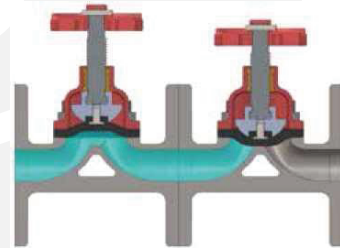

Basic Structure and Mechanism of Diaphragm Valves

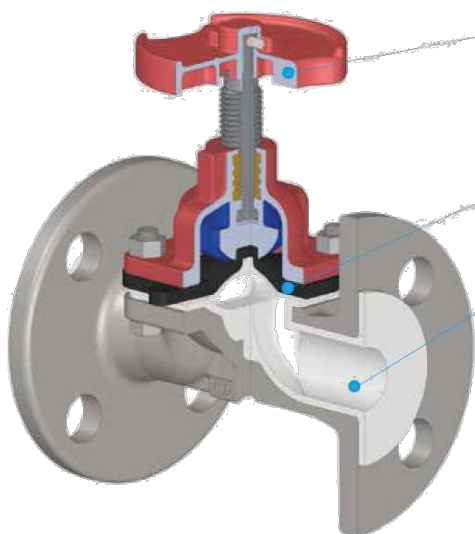

Actuator

Mainly categorized into the manually operated type, pneumatically operated type, flow control type and electrically operated type.

Diaphragm

NBR, EPDM, Butyl, Viton, PTFE Backed EPDM, and other material are available according to application.

Body

Metal with or without lining is available in rich selection for a body.

Lining: Ebonite / EPDM / PFA

Connection method available includes flange type and screw type.

Features:

A) Superb airtightness.

- The operating parts is isolated by the diaphragm. This prevents fluid leakage to outside or contamination of fluid by outside air.

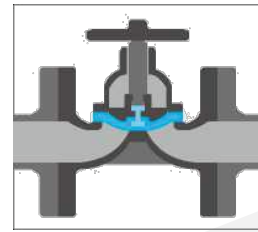

B) Zero leakage from valve seat.

- Controlled by flexible diaphragm, no fluid leaks from the valve seat.
- In the case of rubber diaphragm, complete closing is available, even if some foreign matters are bitten into diaphragm due to its flexibility.

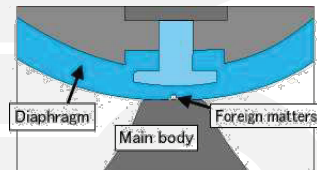

C) Superb corrosion and chemical resistance.

- Simple body shape is suitable for the lining process.
- Combination of rich selection of diaphragm material and various lining bodies such as rubber and fluorine resin allows manufacture of valves applicable to a wide span of fluid specifications, which is more efficient costwise than special alloy combination. Drain port or drain ball valve with NPT end; for in line emptying of condensate or water.

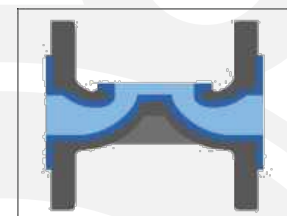

D) Good self-purifying performance.

- Streamlined fluid passage without pockets provides self-purifying performance by minimizing fluid retention.

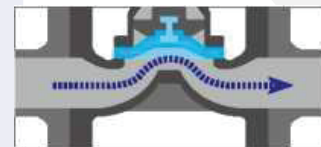

E) Superb maintainability.

- Simple design of three parts. Actuator, Diaphragm and the Body makes it easy to disassemble/assemble the valve.
- Top entry structure adopted enables to change diaphragm by simply removing the nuts and bolts that joint the main body and the bonnet without disconnecting the valve from the piping.
- Each unit is interchangeable, enabling a system change with ease from manual to automatic operation.

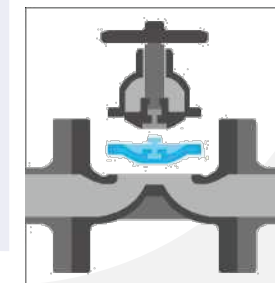

F) Environment-friendly types

- Simple 3-unit construction of the Actuator, Diaphragm and the Body requires less number of parts than other valve types, saving consumable parts.

G) Epoxy painting

H) It is a quick opening valve.

Technical Data

1. Size range: NPS 1/2"~12"
2. Pressure ratings: 150LB
3. Working temperature: -29°C ~ +120°C
4. Suitable Medium: Chemical, environment and water treatment, iron and steel, shipbuilding, medical, food, semiconductor, power generation, etc.
5. Body Material: Ductile Iron / A216 WCB
6. Lining: Ebonite / EPDM / PFA / F46 / F4
7. Diaphragm Material: Butyl, NBR, EPDM, Viton, PTFE Backed EPDM, and other material are available according to application.

Performance Standard

1. Design & Manufacture standard as to: MSS-SP-88
2. Face to Face dimension standard as to: MFR-STD
3. Flange dimension conforms as to: ASME B16.5 RF
Threaded dimension conforms as to: NPT :ASME B1.20.1
BSPT:ISO 228
4. Testing And Inspection as to: API 598
5. Anti Corrosion as per NACE MR-0175 requirement

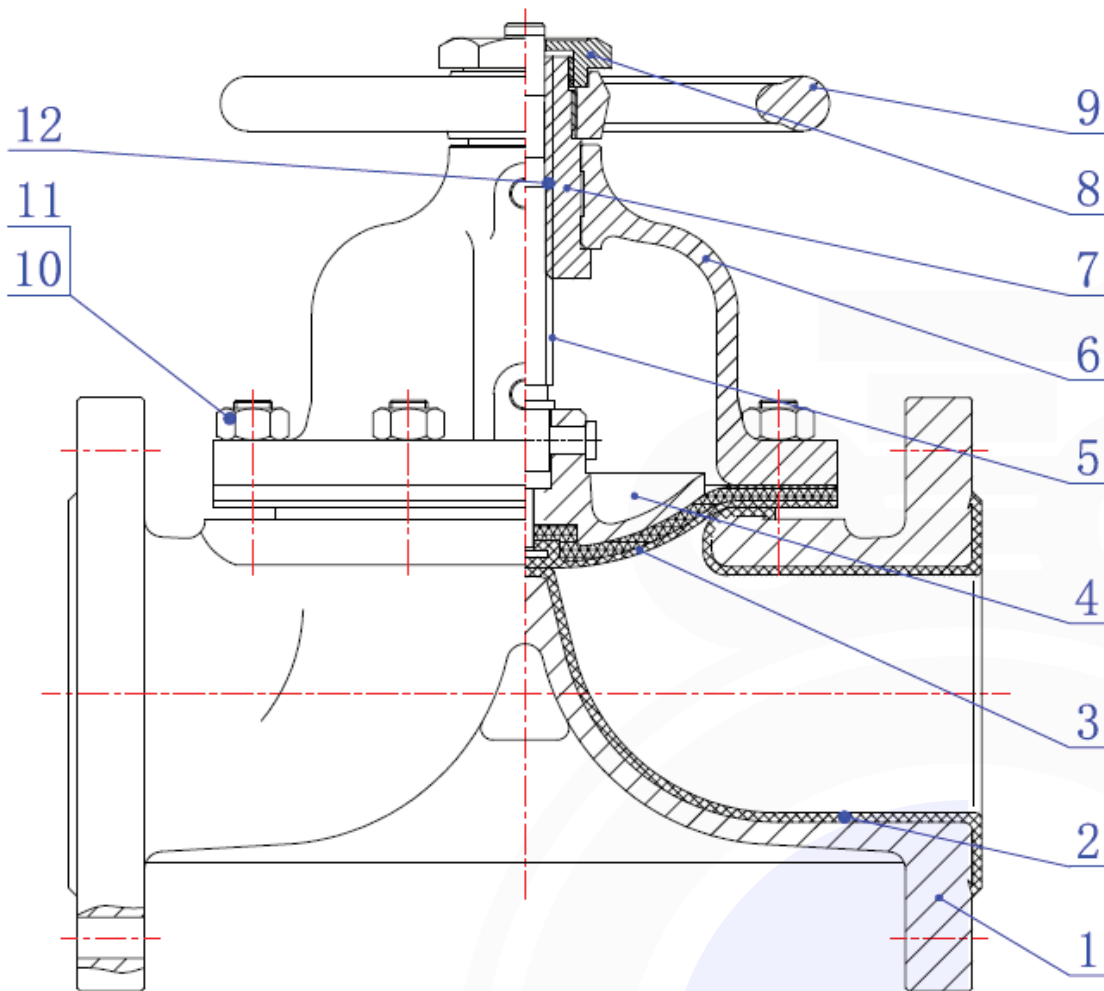

Part List:

Diaphragm Valve WT SBM-PTV

| No. | Part Name | Material | Standard |
|-----|-----------------|---|---------------------|
| 1. | Body | Ductile Iron / Carbon Steel | ASTM A536 /A216 WCB |
| 2. | Lining | Ebonite / EPDM / PFA | USA DuPont |
| 3. | Diaphragm | Butyl / NBR / EPDM / Viton / PTFE Backed EPDM | USA DuPont |
| 4. | Disc | Ductile Iron | ASTM A536 |
| 5. | Stem | Ductile Iron | ASTM A536 |
| 6. | Bonnet | Ductile Iron / Carbon Steel | ASTM A536/ A216 WCB |
| 7. | Stem Nut | Brass | H 62 |
| 8. | Locking Nut | 2H | ASTM A194 |
| 9. | Hand Wheel | Carbon Steel | A216 WCB |
| 10. | Nut | 2H | ASTM A194 |
| 11. | Bolt | B7 | ASTM A193 |
| 12. | Surface Bearing | SF-1 | USA DuPont |

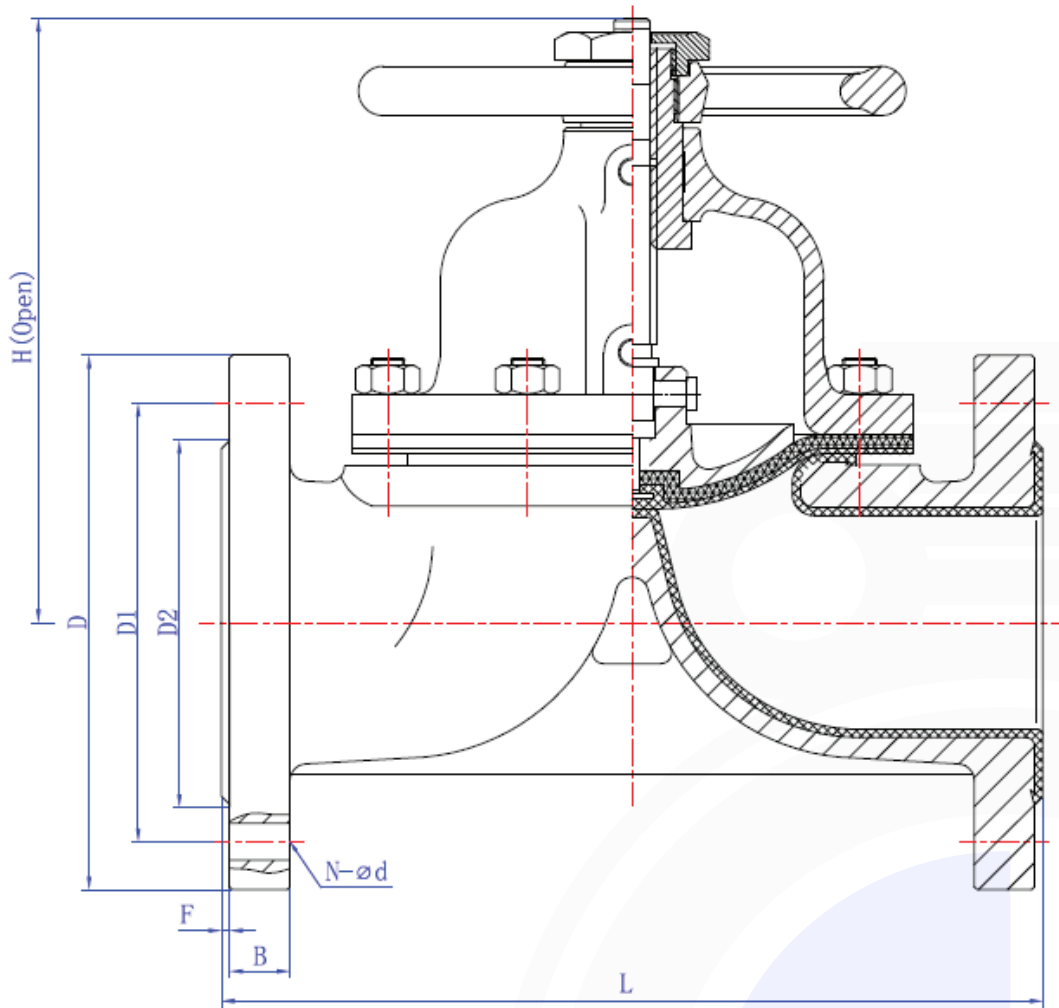

Main Dimensions:

Diaphragm Valve WT Flange 150LB

| NPS | L | D | D1 | D2 | B | N-Φ | F | H | Weight (Kg) |
|--------|-----|------|--------|------|------|----------|---|-----|-------------|
| 2" | 145 | Φ110 | Φ79.4 | Φ51 | 13 | 4-Φ16 | 2 | 135 | 5.5 |
| 1 1/4" | 160 | Φ115 | Φ88.9 | Φ64 | 14.5 | 4-Φ16 | 2 | 150 | 8 |
| 1 1/2" | 180 | Φ125 | Φ98.4 | Φ73 | 16 | 4-Φ16 | 2 | 175 | 11 |
| 2" | 210 | Φ150 | Φ120.7 | Φ92 | 17.5 | 4-Φ19 | 2 | 195 | 14 |
| 2 1/2" | 250 | Φ180 | Φ139.7 | Φ105 | 21 | 4-Φ19 | 2 | 200 | 23 |
| 3" | 300 | Φ190 | Φ152.4 | Φ127 | 22.5 | 4-Φ19 | 2 | 255 | 29 |
| 4" | 350 | Φ230 | Φ190.5 | Φ157 | 22.5 | 8-Φ19 | 2 | 325 | 46 |
| 5" | 400 | Φ255 | Φ215.9 | Φ186 | 22.5 | 8-Φ22 | 2 | 405 | 70 |
| 6" | 460 | Φ280 | Φ241.3 | Φ216 | 24 | 8-Φ22 | 2 | 450 | 95 |
| 8" | 570 | Φ345 | Φ298.5 | Φ270 | 27 | 8-Φ22 | 2 | 600 | 170 |
| 10" | 680 | Φ405 | Φ362.0 | Φ324 | 29 | 12-Φ25.5 | 2 | 620 | 270 |
| 12" | 790 | Φ485 | Φ431.8 | Φ381 | 31 | 12-Φ25.5 | 2 | 680 | 320 |

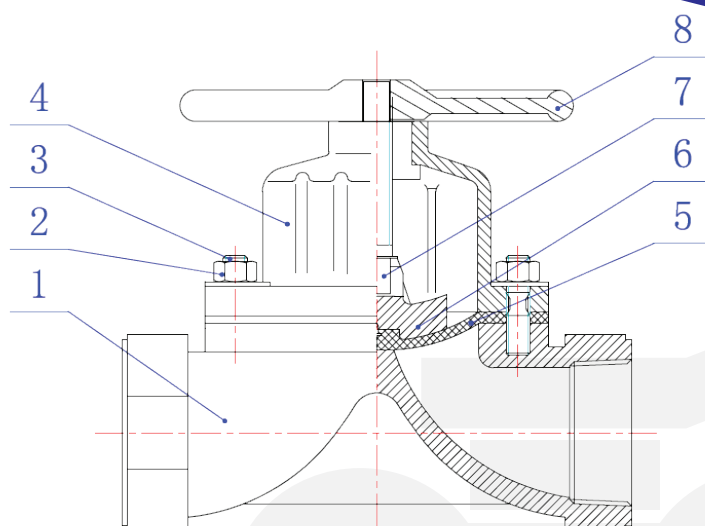

Part List:

Diaphragm Valve WT NPT 150L

| No. | Part Name | Material | Standard |
|-----|----------------|---|---------------------|
| 1. | Body (Unlined) | Ductile Iron / Carbon Steel | ASTM A536 /A216 WCB |
| 2. | Nut | 2H | ASTM A194 |
| 3. | Bolt | B7 | ASTM A193 |
| 4. | Bonnet | Ductile Iron / Carbon Steel | ASTM A536/A216 WCB |
| 5. | Diaphragm | Butyl / NBR / EPDM / Viton / PTFE Backed EPDM | USA DuPont |
| 6. | Disc | Ductile Iron | ASTM A536 |
| 7. | Stem | Ductile Iron | ASTM A536 |
| 8. | Hand Wheel | Carbon Steel | A216 WCB |

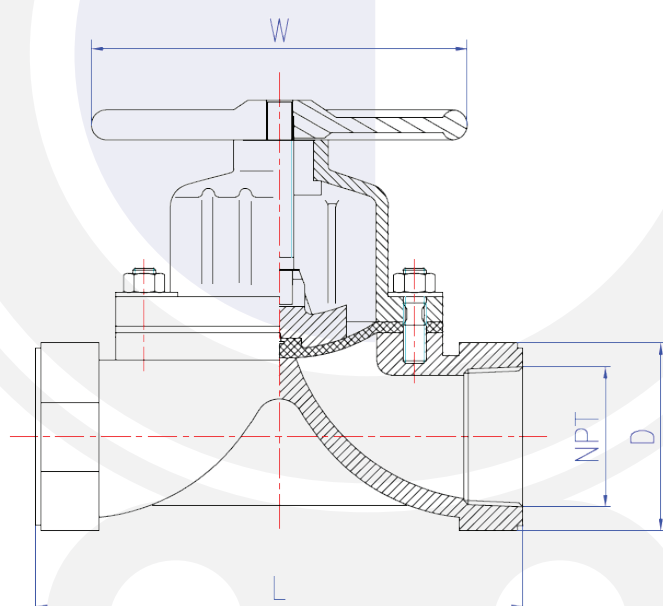

Main Dimensions:

Diaphragm Valve WT NPT 150LB

| NPS | NPT | L | D | W | Weight (Kg) |
|--------|--------|-----|----|----|-------------|
| 1/2" | 1/2" | 65 | 38 | 50 | 1.1 |
| 3/4" | 3/4" | 85 | 40 | 50 | 1.3 |
| 1" | 1" | 110 | 48 | 66 | 1.9 |
| 1 1/4" | 1 1/4" | 120 | 58 | 96 | 3.3 |
| 1 1/2" | 1 1/2" | 140 | 69 | 96 | 4.2 |
| 2" | 2" | 165 | 85 | 96 | 5.8 |

Specific Flow Rate Characteristics (Lining: Rubber)

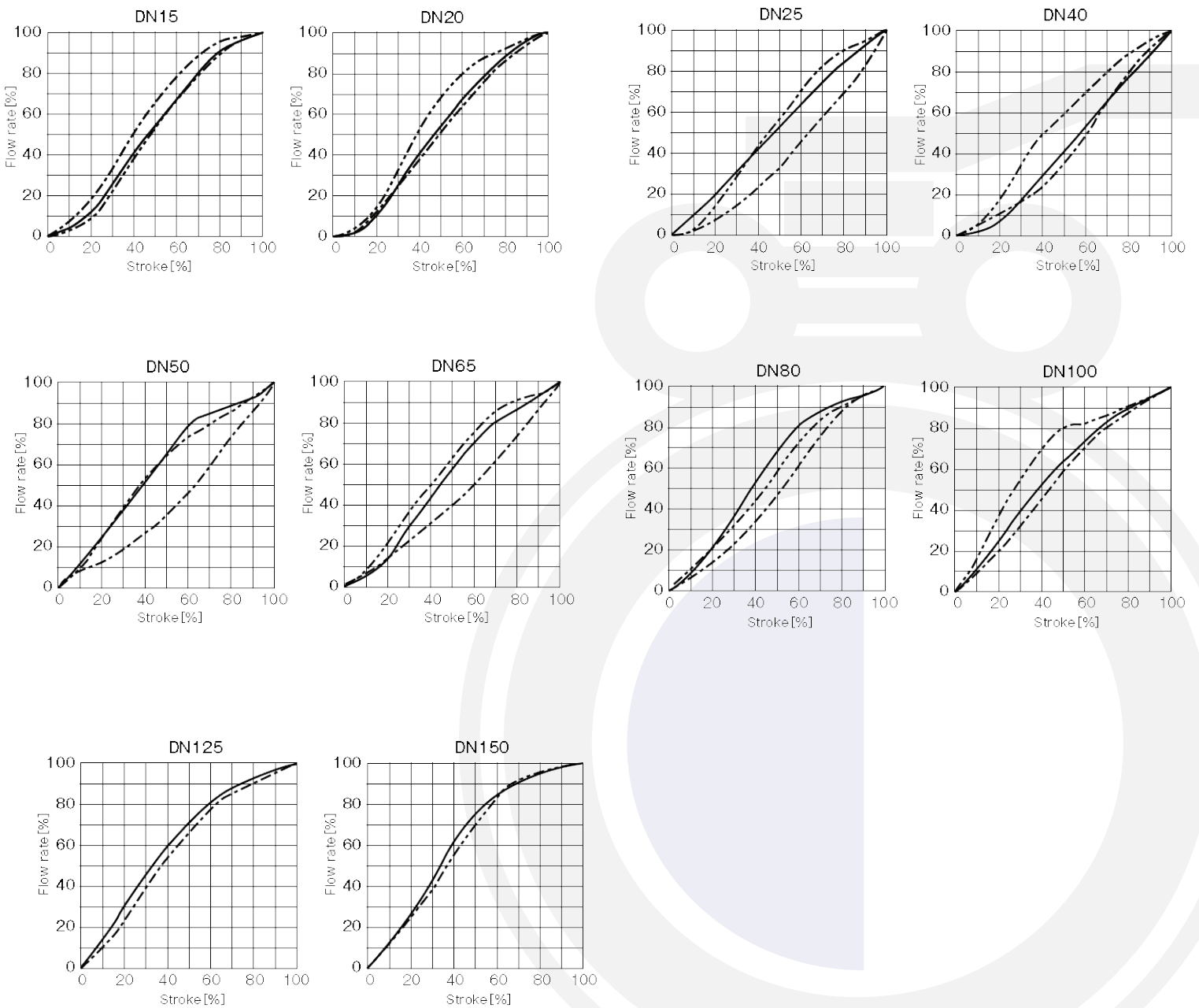

- : Main body without lining - Rubber diaphragm
- - - - - : Main body without lining - PTFE diaphragm*1
- · - · - : Rubber-lined main body - Rubber (or PTFE) diaphragm

*1. DN125 and 150 have characteristics approximately similar to rubber diaphragm.

Specific Flow Rate Characteristics (Lining: PFA)

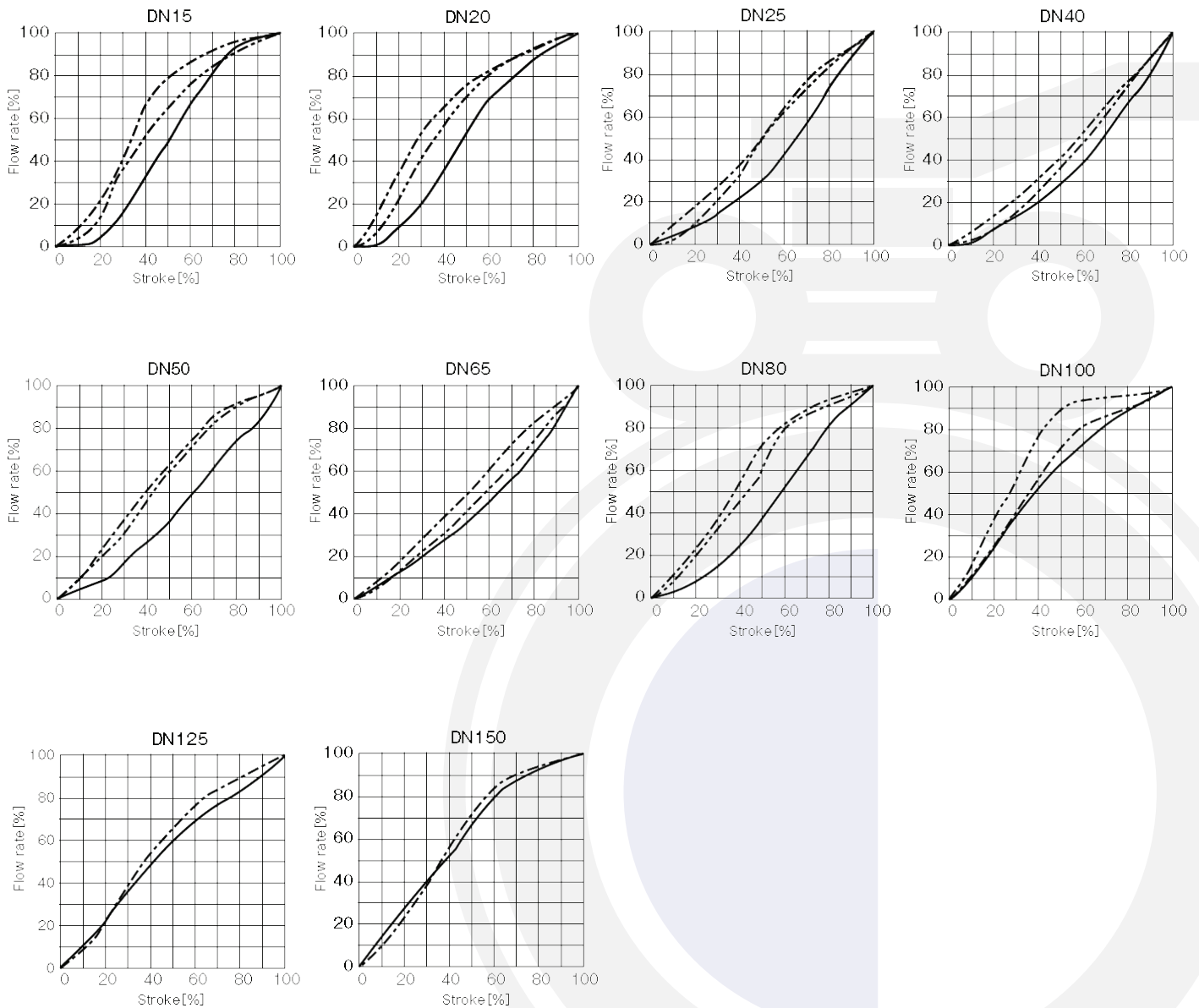

- : Glass-lined main body - PTFE diaphragm
- - - - - : PFA-lined main body - PTFE diaphragm
- · - · - · : ETFE-lined main body - PTFE diaphragm

The charts show the specific flow rate characteristics actually observed by this company. In actual service, the flow rate characteristics may vary depending on the pressure, temperature, flow velocity, piping and other condition.